



defalin
GROUP SA

defalin zwiąże najpewniej

PP STRAPPING TAPES





Defalin Group S.A.

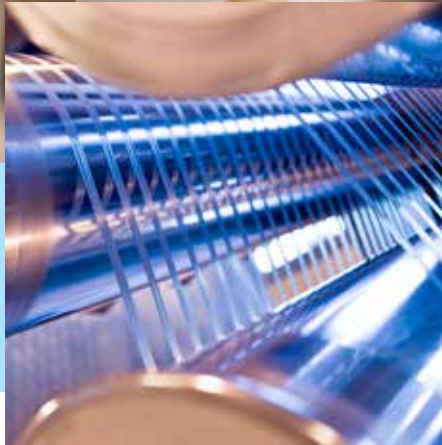

Defalin. Almost 100 years of history, tradition and all growing experience.

The long time, devoted to changes and steady progress so that today we can proudly say:

*defalin binds
the best*

The idea that lays behind our everyday activity is permanently oriented on satisfying needs of our customers to the highest possible extent. Since our target is to manufacture products of the best quality, we constantly invest in modernization of our machines which allows us to apply technologies of the highest world standards.

Long years of experience, consistently modernised technologies of production and high quality of the products manufactured by us allow Defalin to keep the leading position in the branch of agriculture and strapping industry. The DEFALIN brand is well known to Polish farmers who use our agriculture twines such as Heros, Goliat, Tytan,



Atlas or Gigant which effectively facilitate harvesting crops and grass.

Polypropylene tapes were first made by Defalin as a kind of pioneering product on the Polish market, and since 1995 our company have occupied leading position on the market of strapping tapes. Our offer of widely varied assortment of these tapes supports increase of sale every consecutive year.

Basing only and solely on the leading production technologies, Defalin Group S.A. can offer products of exceptionally high quality which successfully compete with those offered by the well known world companies on the international markets.

Defalin's products have been present on the markets abroad since many years. We export our goods to nearly all countries of the European Union, Eastern Europe, Middle East and North America. One of our big advantages is that we are able to meet variable specific requirements of our clients, so that our products can be best adjusted to their particular local conditions.

Defalin Group S.A. carry out intensive activities aiming at the effective marketing communication. Our promotion campaigns are directed promptly to the consumers as well as to our business partners. Every half a year we supplement the catalogues of our products and we strongly invest in electronic media

along with participation in fairs and exhibitions on domestic and foreign market at home and abroad.

The effective strategy of leading manufacturer on the Polish market and well founded position on the European markets we can accomplish basing on our very professional and deeply engaged team, where long experience of the longtime specialists meet with enthusiasm of the younger ones.

Distribution companies, post offices and banks

With the production started 20 years ago, Polypropylene Strapping Tapes have become one of the well known and highly valued products made by DEFALIN GROUP S.A. Thanks to modern and high-yield production technology, wide assortment of these tapes as offered by us can fully satisfy various needs arising on the markets. Their perfectly straight linearity, outstanding welding ability as well as fail-safe tenacity are the qualities allowing for vast application in many branches of industry and services, with making use of automatic or manually operated packaging equipment.



Distribution companies, post offices and banks PP tapes 4-8 mm

PP tapes of 4-8 mm width (tenacity from 53 to 105 daN) are used for tight-wrapping products of lower weight, like letters in post offices, wads of banknotes in banks and files of documets in offices.

Specification of the tapes :

Width (mm)	4 - 8
Thickness (mm):	0,35 - 0,60
Application	automatic and semi-automatic strapping equipment
Break strength approx (daN):	35 - 105



The foamy PP tape is designed for tying up delicate products of smaller size in the special packaging equipment. These tapes are being used always when a parcel is to be tied up most securely and with guarantee that a product will not get damaged in course of packing process. They are perfect for tying up small delicate boxes, bank notes, files, books etc.



The background of the entire page is a photograph of a printing shop, showing several large rolls of paper stacked on a conveyor belt or in a storage area. The image is heavily filtered with a blue color, creating a monochromatic effect. The rolls are arranged in a way that creates a sense of depth and repetition.

Paper industry and printing shops



Paper industry and printing shops

PP tapes 4-10 mm

PP tapes of 4-10 mm width can be used for both machine and manual strapping. They are perfect for strapping packets, sheets of paper and cardboard, newspapers and catalogues in automatic production lines.

Specification of the tapes :

Width (mm)	4 - 10
Thickness (mm):	0,35 - 0,60
Application	automatic and semi-automatic strapping equipment / manual strapping devices
Break strength approx (daN):	35 - 115



Household goods



Small products PP tapes 4-10 mm



Packaging process as employed in automatic packaging lines, where both accuracy and duration of strapping are the factors of special importance, require using tapes of extremely high technical qualities. Applying the new diagonal mollet (marked with „U”) has enabled us to obtain tape of increased stiffness that results in accurate feeding into the opening of strapping automat, while smooth surfaces of both sides of the tape make the feeding easier. Also, these our tapes show the dust emittance reduced by 50% and are distinguished by the decreased friction coefficient as well as by lower crescenty.

The tape marked with „U” is a product characterized by the unique mollet which had been patented by DEFALIN GROUP S.A.

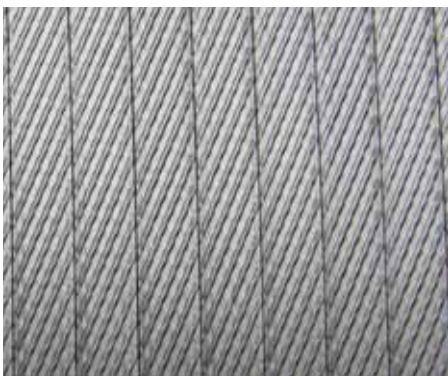

Specification of the tapes :

Width (mm)	4 - 10
Thickness (mm):	0,35 - 0,60
Application	automatic and semi-automatic strapping equipment
Break strength approx (daN):	35 - 115



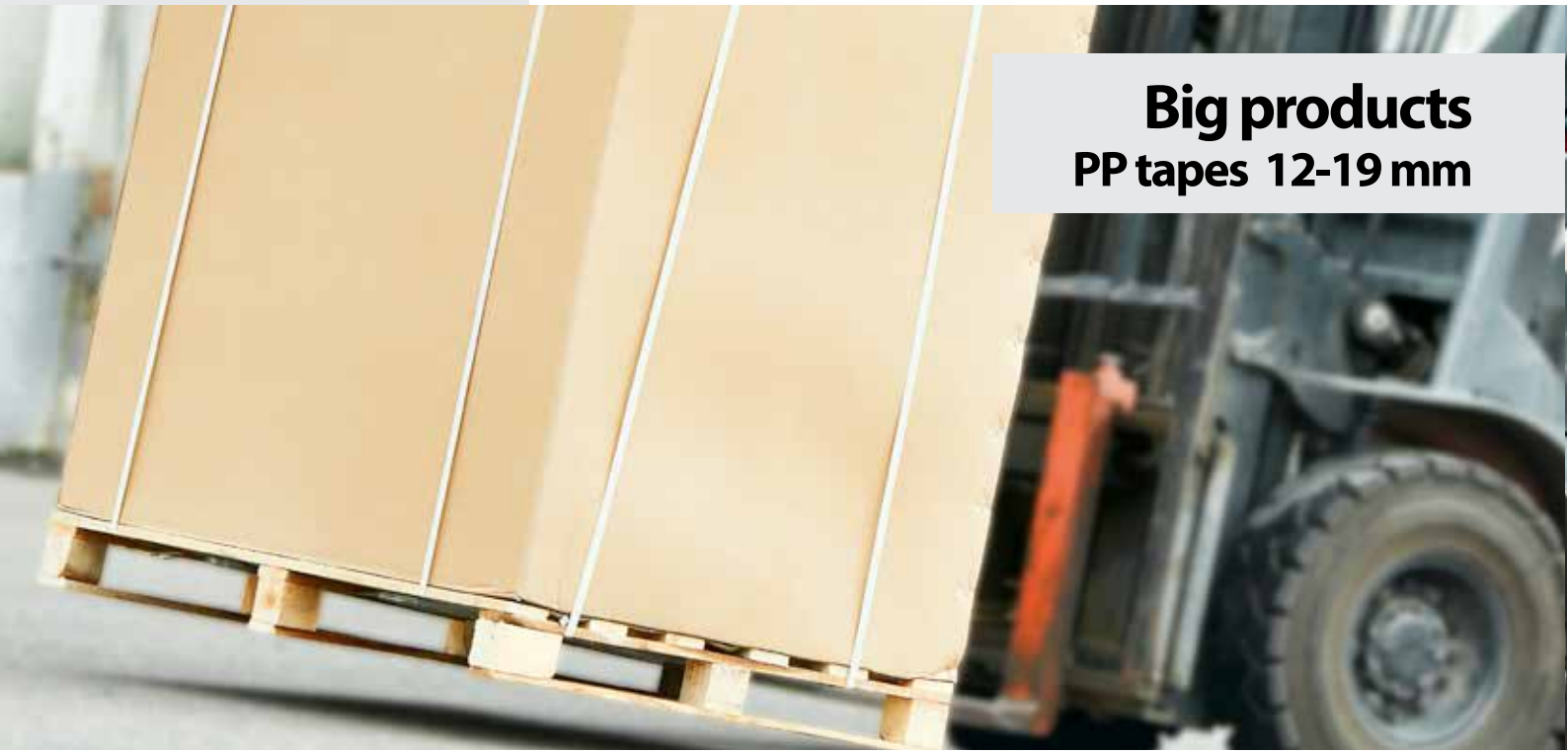

Big products

PP tapes 12-19 mm



Specification of the tapes :

Width (mm)	12 - 19
Thickness (mm):	0,50 - 0,90
Application	automatic and manual strapping devices
Break strength approx (daN):	142 - 405

Using the PP tapes 12-19 mm is especially recommended for securing pallets during transportation. These tapes are dedicated for strapping process in the automatic production lines as well as with use of hand-strapping devices.

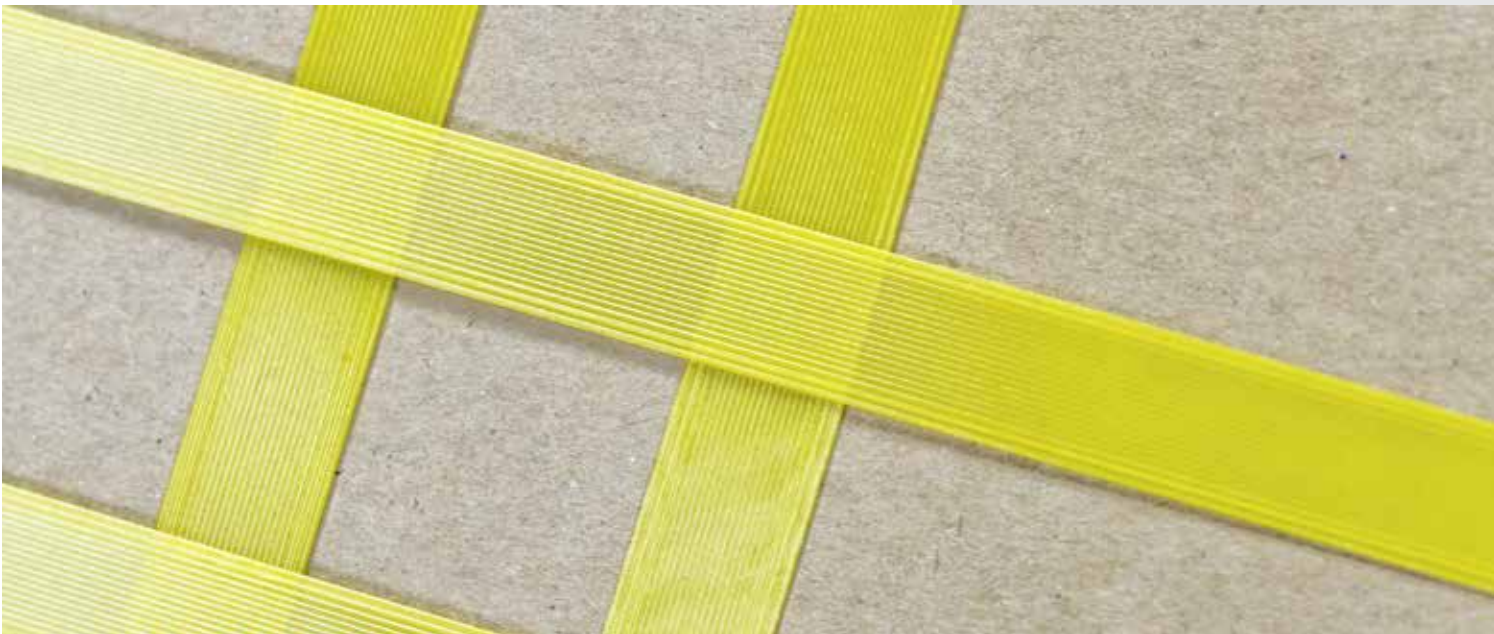

Mono PP tapes 9-10 mm

Mono is a tape of unique linear molet and it is noted for its remarkable flexibility and stretchability. Edges of the tape are rounded off so that they will not damage the cardboard boxes when wound up in automatic packaging equipment. Perfect straight-linearity and no emittance of dust provide for failure-free work in the machine. This tape keeps the goods perfectly stabilized during transport and its high tenacity against breakages as well as max. elongation of 24%, make possible using a narrower tape (therefore less expensive in exploitation) for tying up the goods of bigger sizes.



Specification of the tapes :

Width (mm)	9-10
Thickness (mm):	0,40 - 0,47
Application	automatic and manual strapping devices
Break strength approx (daN):	142 - 405
Tape length (m):	4100

On customer's request, the tapes can be made in colours other than natural, white or black. Also, we can make overprint the tape in accordance with any particular client's specification.

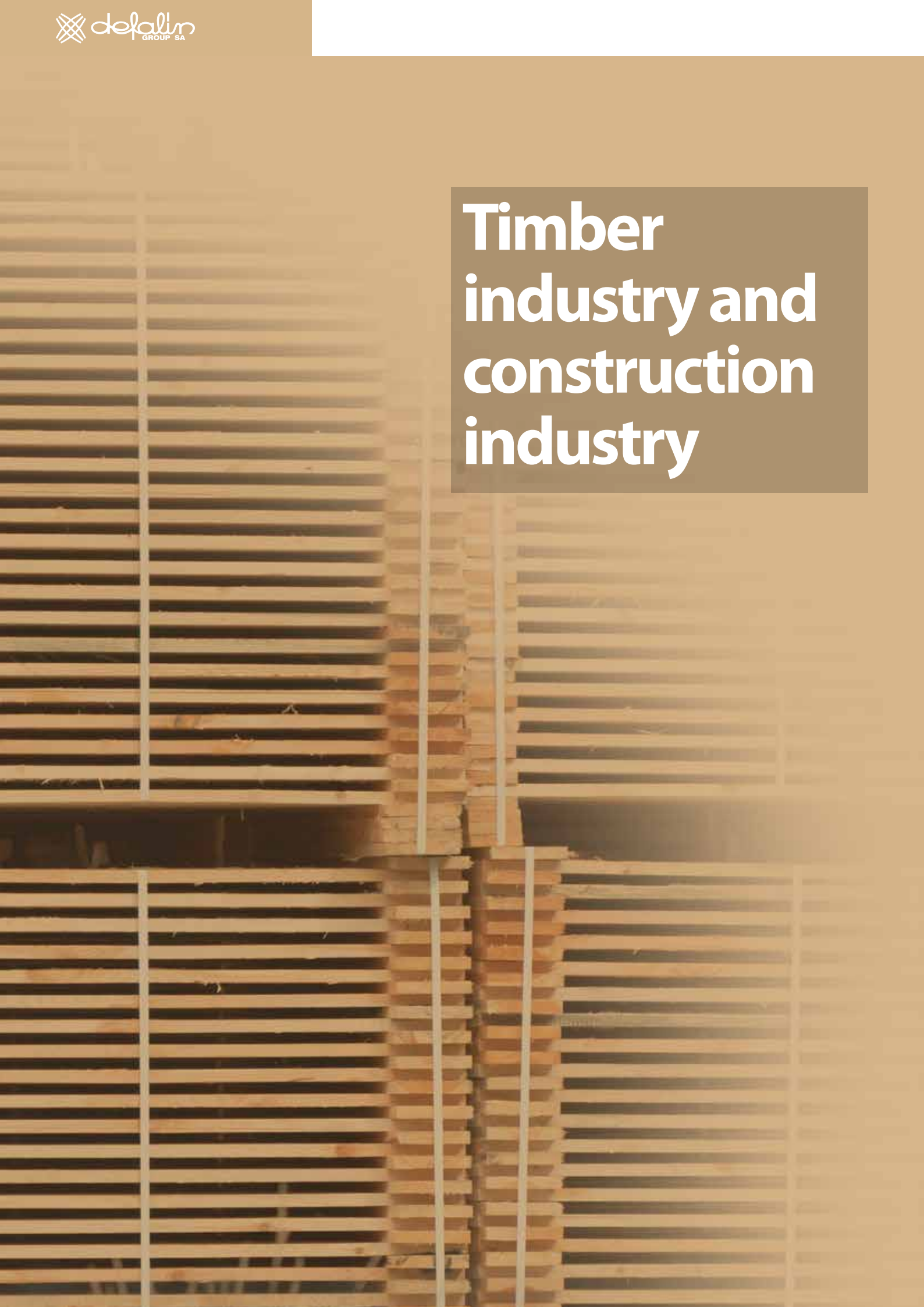

The background of the page is a close-up photograph of several stacks of light-colored wooden planks. The planks are arranged in neat, vertical stacks, with some stacks being taller than others. The lighting is warm, highlighting the natural grain and texture of the wood. The overall composition is clean and professional, emphasizing the raw material of the timber industry.

Timber industry and construction industry



PP tapes of 405 daN tenacity are recommended for securing pallets during transportation. This kind of tapes is being used also in sawmills, ceramic industry and brickyards as well as for strapping heavy loads of any type.



Specification of the tapes :

Width (mm)	12 - 19
Thickness (mm):	0,50 - 0,90
Application	automatic and manual strapping devices
Break strength approx (daN):	142 - 405



SPEND - TUBELESS COIL

The PP SPEND tapes are ideal for manual strapping of loads. Handy cardboard box containing the tape and convenient hand grip allows for efficient and quick relocating as well as for easy use of the tape.

PP TAPES

Code	Tube Type	Inner diameter	Tape length	Breaking strength approx	Number of coils per carton box	Number of cartons box per pallet
		Sw (mm)	L (m)	daN	pcs.	pcs.
4040	D	200	6000	34	1	60
5035	A	63	2500	53	4	60
5035	C1	185	5500	53	1	60
5040	A1	200	2300	50	4	60
5040	C1	150	5500	50	1	60
5040	D	200	7000	50	1	60
5045	B	150	6000	52	1	60
5045	D	200	7000	52	1	60
5050	A	63	2100	60	4	60
5050	B	150	6000	60	1	60
5050	D	200	6000	60	1	60
6050	D	200	5500	65	1	60
6055	D	200	5100	92	1	60
8050	D	200	4500	89	1	60
8055	D	200	4500	101	1	60
8060	D	200	4500	105	1	60
9050	D	200	3700	105	1	60
9050	D	200	4800	105	1	60
9055	D	200	4000	107	1	60
9055	D	200	4500	107	1	60
9070	E	280	2500	140	1	60
10050	D	200	4100	115	1	60
12050	D	200	3400	142	1	60

Code	Tube Type	Inner diameter	Tape length	Breaking strength approx	Number of coils per carton box	Number of cartons box per pallet
		Sw (mm)	L (m)	daN	psc.	psc.
12055	D	200	3000	150	1	60
12060	D	200	2800	155	1	60
12060	E	280	2200	155	1	60
12080	G	406	2000	225	1	48
14050	D	200	3000	170	1	60
15060	D	200	2200	225	1	60
15080	D	200	1700	275	1	60
15080	G	406	1600	275	1	48
16060	D	200	2000	240	1	60
16060	G	406	1800	240	1	48
16080	D	200	1500	310	1	60
16080	G	406	1400	310	1	48
19090	D	200	1200	405	1	60

SPENDEN

Code	Tube Type	Package Size	Tape length	Breaking strength approx	Number of coils per carton box	Number of cartons box per pallet
		Sw/Sz x S (mm)	L (m)	daN	psc.	psc.
12050	-	200/355x355	1100	142	1	60
12055	-	200/355x355	1000	150	1	60
12060	-	200/355x355	1000	155	1	60

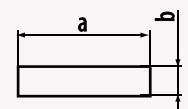
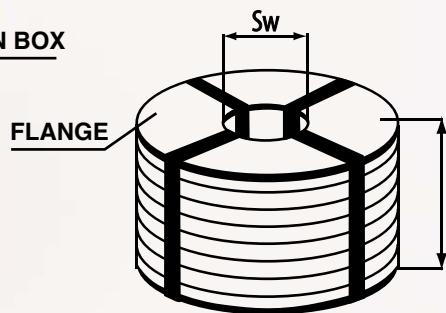
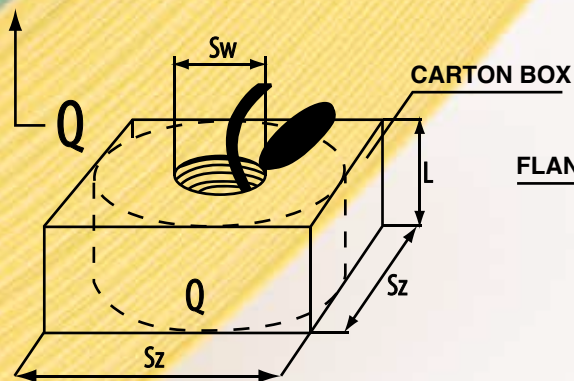

TAPE DIMENSIONS

a - width
b - thickness

CODE CLARIFICATION

8060;
a = 8 mm
b = 0,60 mm

ATTENTION!!!

Addition of UV stabilizer allows for the tapes to be used in the open air, with presence of UV radiation, for a period of 0.5 up to 1 year. In case of tapes of colours other than white, the UV stabilizer is being added on customer's request.



defalin
GROUP SA

defalin zwiąże najpewniej

P.P.H.U. „Defalin” Group S.A.

ul. Towarowa 16
58-160 Świebodzice, Poland

Sales Department:

tel.: +48 74 854 99 83

fax +48 74 854 99 29

e-mail: dhws11@defalin.com.pl

tel.: +48 74 854 99 88

fax +48 74 854 99 29

e-mail: dhws3@defalin.com.pl

Join our community and be supplied with the latest news on Defalin.



facebook.com/DefalinGroup



twitter.com/DEFALINGROUP

www.defalin.com.pl

This brochure is meant to only give a general description and information. It may be changed and is neither a commercial offer, nor a description of actual state, and is not a guarantee issued or suggested by Defalin Group S.A. Before taking decision of purchase of any goods on the basis of this brochure, it is necessary to contact directly the commercial department of Defalin so that its relevance with regards to particular items of interest can be confirmed. Defalin reserve the right to change specification of materials and description of products in any time and without warning as well as to cease offering a particular version of product. Due to constant development of the offered products as well as other production factors and norms, the currently available kinds of products materials and specifications may differ from the ones as presented in this brochure.

